

TAMPA MONTANTE CHROMA MINIMALISTA NYL C/4PCS (TAM107/213)



CARACTERÍSTICAS

CODIFICAÇÃO		
COR	CÓDIGO	CATÁLOGO
BCO	9302555	TAMCHROMA107213NYBCO
PRT	9302556	TAMCHROMA107213NYPRT

OBSERVAÇÕES

COMPOSIÇÃO/CARACTERÍSTICAS:

- TAMPA: POLÍMERO.

APLICAÇÃO NOS PERFIS:

- CHR-213 E VT-1000.

APLICAÇÃO

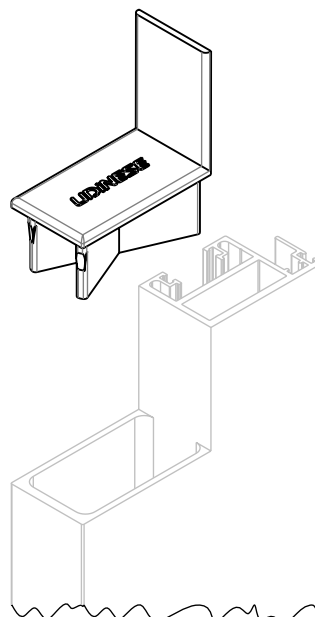

ESCALA 1 : 2

USINAGEM

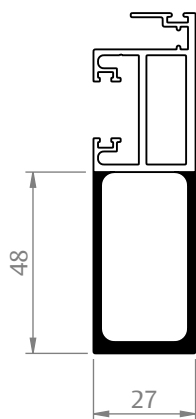
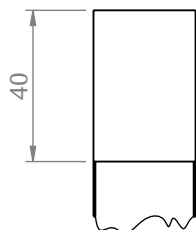

ESCALA 1 : 2

DIMENSÕES

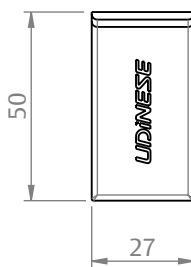
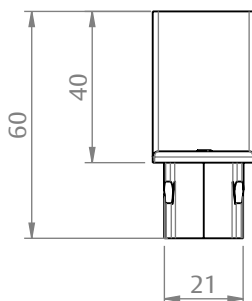

ESCALA 1 : 2

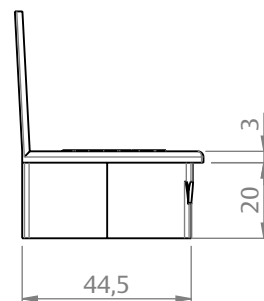

**PORTA E JANELA
DE CORRER**

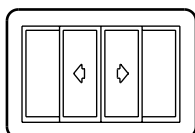

UDINESE
ASSA ABLOY