

BRAÇO SUPREMA

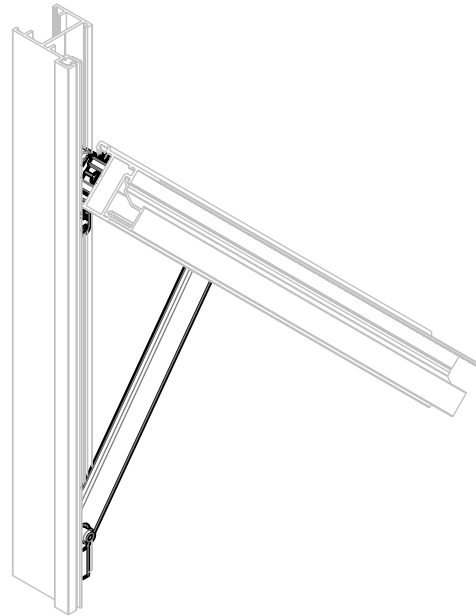

APLICAÇÃO



ESCALA 1 : 3

CARACTERÍSTICAS

CODIFICAÇÃO			
VERSÃO "A"	COR	CÓDIGO	CATÁLOGO
180	BCO	9102634	BRASUP180BCO
	PRA	9102804	BRASUP180PRA
	PTF	9102637	BRASUP180PTF
250	BCO	9101596	BRASUP250BCO
	PRA	9102784	BRASUP250PRA
	PTF	9101440	BRASUP250PTF
	BP3	9102939	BRASUP250BP3
	CZ7	9103409	BRASUP250CZ7
	S/A	9103355	BRASUP250S/A
400	BCO	9101603	BRASUP400BCO
	PRA	9102786	BRASUP400PRA
	PTF	9101506	BRASUP400PTF
	BP3	9102934	BRASUP400BP3
	CZA	9103406	BRASUP400CZ7
S/A	9103350	BRASUP400S/A	
500	BCO	9101594	BRASUP500BCO
	PRA	9102785	BRASUP500PRA
	PTF	9101441	BRASUP500PTF
	BP3	9102936	BRASUP500BP3
	CZA	9103408	BRASUP500CZ7
	S/A	9103352	BRASUP500S/A
750	BCO	9101595	BRASUP750BCO
	PRA	9102783	BRASUP750PRA
	PTF	9101442	BRASUP750PTF
	BP3	9102937	BRASUP750BP3
	S/A	9103353	BRASUP750S/A
810	BCO	9101783	BRASUP810BCO
	PRA	9102789	BRASUP810PRA
	PTF	9101782	BRASUP810PTF
	BP3	9102935	BRASUP810BP3
	CZA	9103407	BRASUP810CZ7
	S/A	9103351	BRASUP810S/A

DIMENSÕES

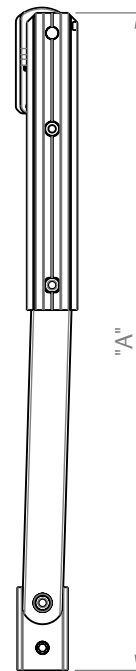

ESCALA 1 : 3

OBSERVAÇÕES

COMPOSIÇÃO/CARACTERÍSTICAS:

- ESTRUTURAS E REBITES: ALUMÍNIO;
- ARRUELAS, BOTÕES E CARRINHOS: POLÍMERO;
- PARAFUSOS: AÇO INOX.

MAXIM-AR

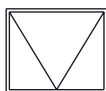

VERSÃO	FOLHA (mm)		LARG.	VIDRO	CARGA
	Mín.	Máx.			
180	200	300	750	4	4
250	270	500	750	6	6
400	400	650	750	6	8
500	520	810	750	6	10
750	810	900	750	6	11
810	900	1200	750	6	15

UDINESE
ASSA ABLOY

BRAÇO SUPREMA

INSTRUÇÕES DE MONTAGEM

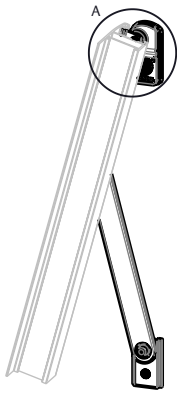

ESCALA 1:5

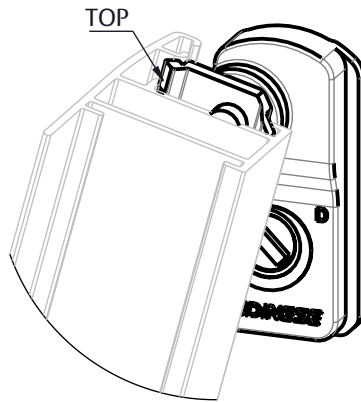

DETALHE A
ESCALA 1:1

PASSO 1:

O SASH DEVE SER ENGAVETADO NO MONTANTE VERTICAL DO PERFIL ATÉ BATER NO "TOP". APÓS ESTA OPERAÇÃO, REALIZE O APERTO DOS PARAFUSOS ALLEN.

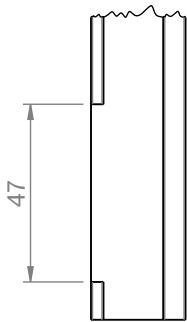

ESCALA 1:2

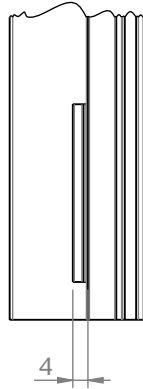

PASSO 2:

REALIZE A USINAGEM DE ENCAIXE DA FOLHA NO MARCO.

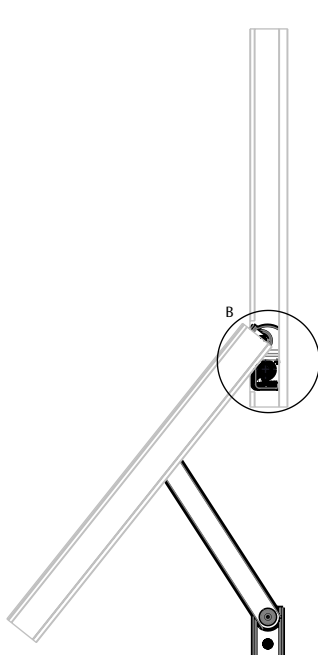

ESCALA 1:5

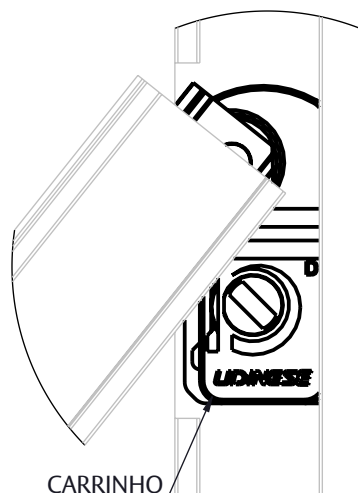

DETALHE B
ESCALA 1:1

PASSO 3:

ENCAIXE O CARRINHO NA USINAGEM DO MARCO. DEPOIS DISSO, LEVANTE A FOLHA PARA QUE O PATIM POSSA SER ENCAIXADO.

BRAÇO SUPREMA

INSTRUÇÕES DE MONTAGEM

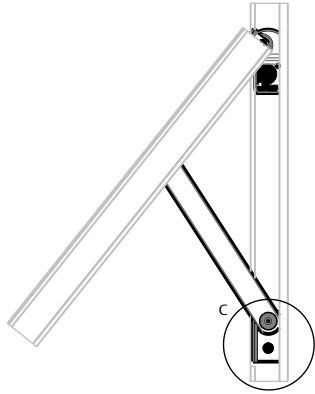

ESCALA 1:5

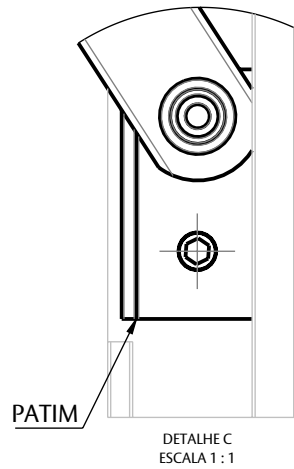

PASSO 4:

APÓS LEVANTAR A FOLHA, ALINHE E ENCAIXE O PATIM NO MARCO. COM O PATIM ENCAIXADO, FAÇA A FIXAÇÃO APERTANDO O PARAFUSO ALLEN.

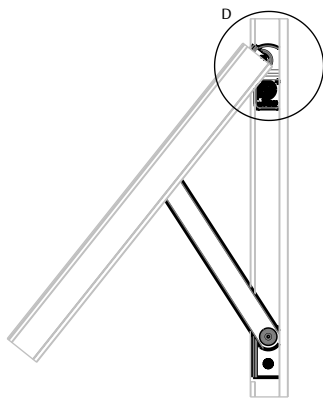

ESCALA 1:5

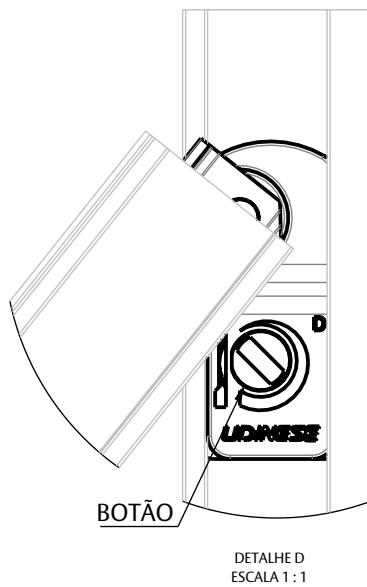

PASSO 5:

APÓS FINALIZAR A INSTALAÇÃO DOS BRAÇOS NA FOLHA E MARCO, É NECESSÁRIO CHECAR A REGULAGEM DO FREIO, OU SEJA, REGULAR A FIRMEZA COM QUE O BRAÇO VAI SE MANTER ABERTO BEM COMO A FORÇA NECESSÁRIA PARA ABRI-LO.

PARA REGULAR O FREIO, UTILIZE UMA CHAVE DE FENDA* NO BOTÃO. GIRE NO SENTIDO HORÁRIO PARA AUMENTAR O FREIO E NO SENTIDO ANTI-HORÁRIO PARA DIMINUI-LO.

*NÃO FORNECIDA PELA UDINESE.

BRAÇO SUPREMA

APLICAÇÕES

SUPREMA (HYDRO)

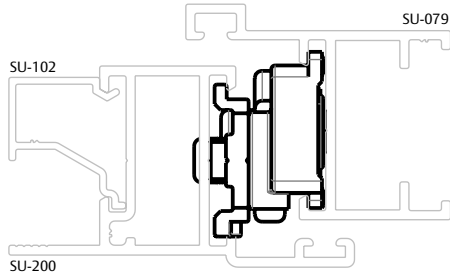

ESCALA 1 : 1

ABSOLUTA (CDA)

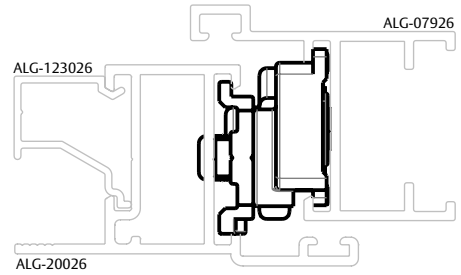

ESCALA 1 : 1

ECOLINE 2.5 (PERFIL ALUMÍNIO)

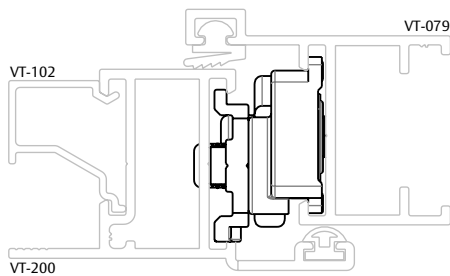

ESCALA 1 : 1

UNNION (PERFIL ALUMÍNIO)

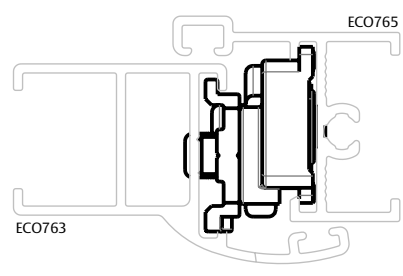

ESCALA 1 : 1

AGLO 2.5 (OLGA COLOR)

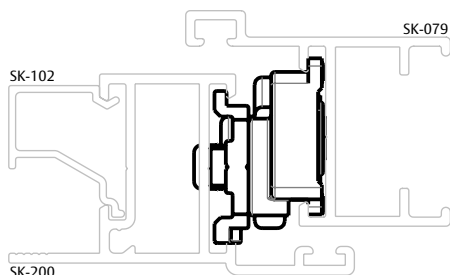

ESCALA 1 : 1

PRIME 2.5 (ALUPRIME)

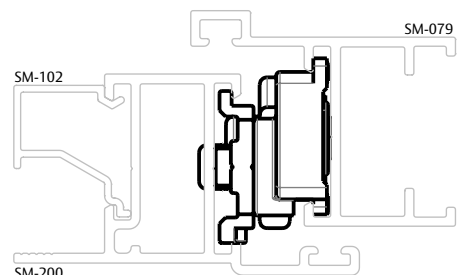

ESCALA 1 : 1